

G503 WWII Fuel Pump Install

This Article describes how to install your WWII Jeep Go Devil Engine Fuel Pump. Applies to 1942,42,1943,43,1944,44,1945 Jeeps models



Installing a fuel pump is easy if you have everything removed and out of the way. If not, one of the two bolts will give you havoc because its difficult to reach.



Before you install your fuel pump look at what is going to get in the way first. The top brass fitting **MUST** be installed on your pump first, because you will not have any room to spin it once your pump is tightened down. The other issue is how to reach the bolt on the left that holds the pump to the block.



(Optional) If you want a good seal, then you can add a little sealer around the gasket prior to installing. Here you see to much sealer, smear this around the gasket with your finger and remove excess.



(Tip from Pete Silfven) Before installing, rotate the engine so the fuel pump cam is all the way down. Using a 1/4 inch drive extension and a short 1/2 inch socket, insert the front bolt into the pump. Then install the whole thing on the engine using the extension and socket to start the front bolt.



Insert the fuel pump and line up the two bolts to the block. You may need a swivel socket to reach the left bolt on the fuel pump. If you applied gasket sealer, then wipe off any excess. Keep the pump rotated slightly counterclockwise so you don't have to work against spring tension while starting the front bolt. After it's started, swing the pump clockwise so the rear hole matches up and install the rear bolt

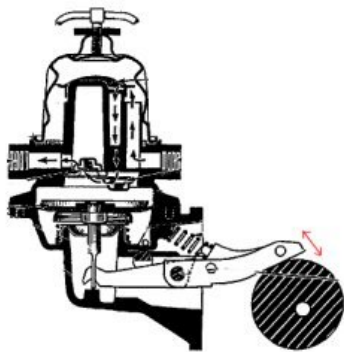

FIG. 12—FUEL PUMP

For reference, the fuel pump arm will sit on the cam shaft, and as the cam shaft rotates the lever on the pump will go up and down thus pumping the fuel.